

DIMENSIONS

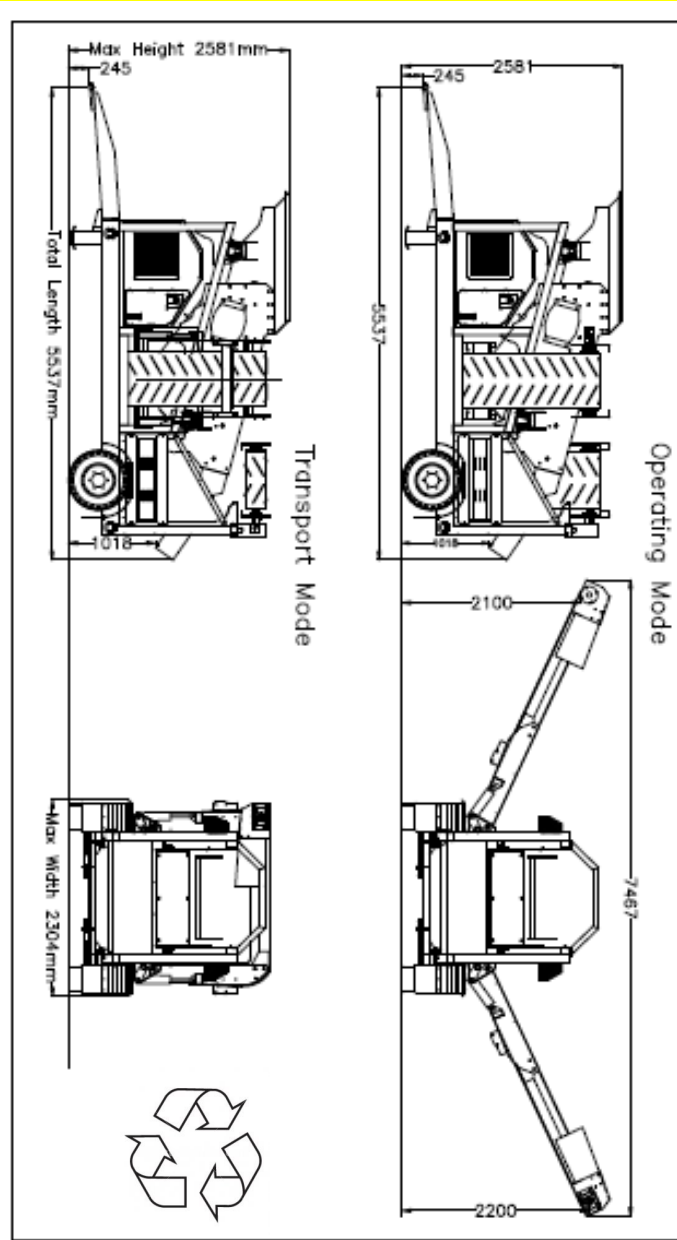

FEATURES & BENEFITS

- Towable behind any Agricultural Tractor
- High performance 2 deck Screener
- Liquid Cooled Diesel Engine—Net Engine Power of 27kW.
- An efficient and simple diesel powered hydraulic system throughout.
- 10' x 4' Top Deck with Direct Feed
- Fines & Mid Size Grade Discharge Conveyors
- Discharge Chute for Over Size, with Over Size Conveyor, **as an option!**
- Hydraulically folding conveyors with excellent stockpiling capacity
- Designed for a wide range of materials and aggregates - Numerous screening media options to consider
- Fits easily into shipping containers
- Minimal setup time, once on site
- Hydraulic Braking and LED Road Lights

HERBST COMPAC SCREEN

Unladen Weight (Kg)	5,450
Transport Length (mm)	5537 (18'2")
With Over Size Chute Only	6722 (22'0")
With Over Size Conveyor	
Transport Width (mm)	2304 (7'6")
Transport Height (mm)	2581 (8'5")
Working Length (mm)	5537 (18'2")
With Over Size Chute Only	8000 (26'3")
With Over Size Conveyor	
Working Width (mm)	7467(24'6")
Working Height (mm)	2581 (8'5")
Top Deck (mm)	3000 x 1200 (10' x 4')

NEW

HERBST

Product Leaflet



Compac Screen



HERBST MACHINERY LTD

120 Drumnakilly Road,
Omagh, Co. Tyrone, N. Ireland. BT79 0JT

Tel: +44 (0)28 8077 1568

Mobile: +44 (0)79000 80380

General: info@herbst.co.uk

Sales: ashley@herbst.co.uk



Available Worldwide
Contact us for Nearest Agent

www.herbstmachinery.com

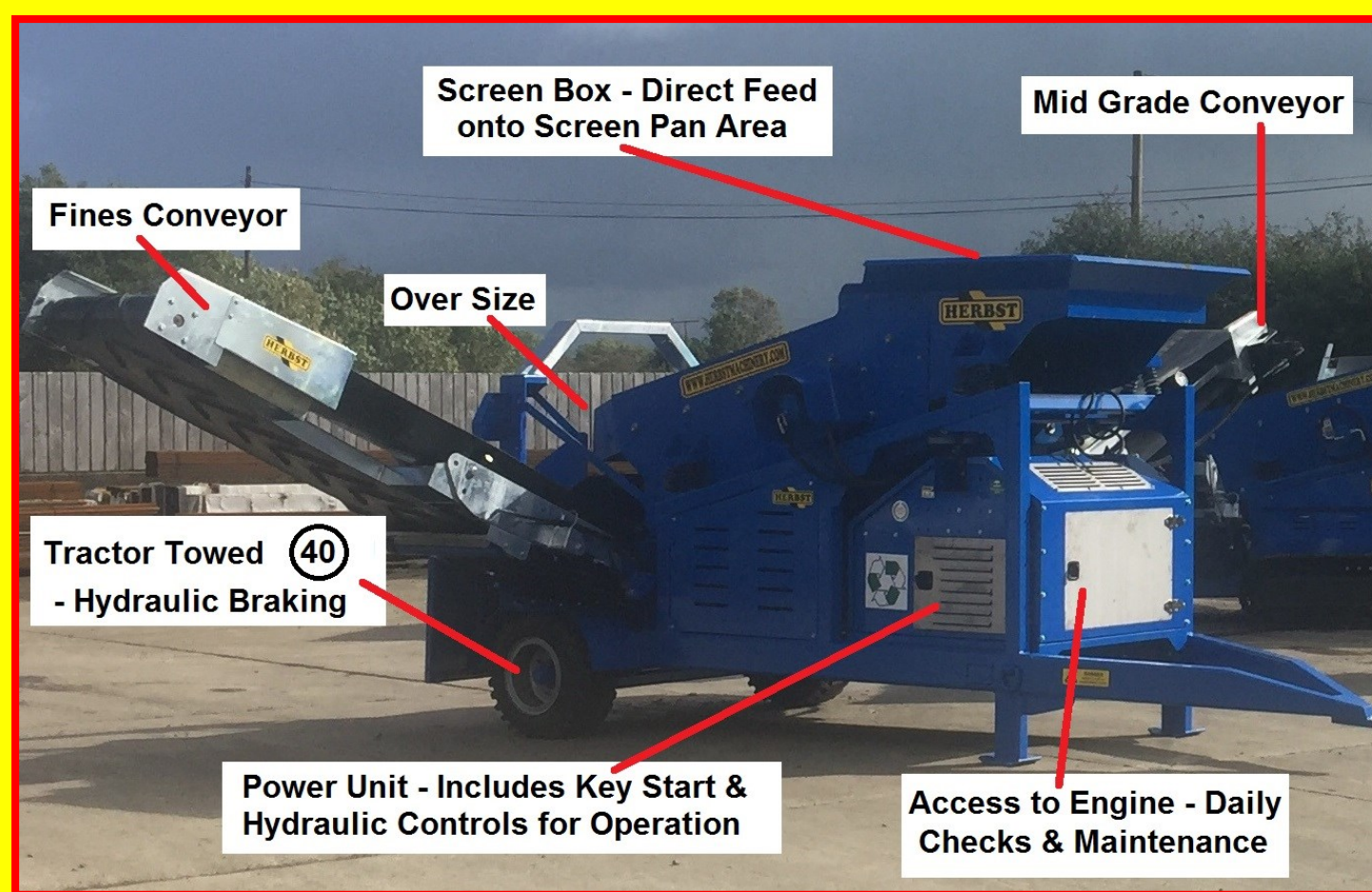

The Compac Screener is designed for transportation behind an agricultural tractor. With a high performance 2 deck screen box, it will process a wide range of materials and aggregates. The hydraulically folding conveyors and unique compact build, allows the screen to be folded up and containerised very easily. The 10' x 4' Top Deck, includes the Pan Feeder / Loading Area, with a screening area of 7' x 4'. The aggressive screening box is capable of processing up to 150 Tonne / Hour, and can be adapted for a variety of applications, including Recycling, Demolition, Crushed stone, Sand & Gravel, Soil & Compost. The simple power unit and hydraulics, results in easy maintenance, operating and servicing.