



AG700 CRUSHER



HERBST AG700 CRUSHER

Compact. Versatile. Built for on-site crushing.

- 700 x 400 mm jaw crusher
- Direct feed hopper
- PTO-driven hydraulic system
- Adjustable crush size: 40–125 mm
- Output: 30 - 60 TPH
- Adjustable jaw setting
- Unladen weight: 8,500 kg
- Handles material up to 350 mm
- Removable discharge conveyor

AG700 Applications:

Recycling, Construction, Demolition, Groundworks, Agricultural Crushing

Materials Processed:

Stone, Concrete, Brick Hardcore, Demolition Waste, Reclaimed Asphalt



Got Questions? Scan to chat on WhatsApp!



Scan for video demonstrations



AG700 Overview

The AG700 is a compact and efficient 700 x 400 jaw crusher, designed for reliable on-site crushing across a wide range of applications.

Powered directly from the tractor PTO, the AG700 operates all hydraulic functions through a simple, integrated system — delivering dependable performance with minimal setup.

Material is fed into the jaw via a direct-feed hopper, with adjustable crush size allowing operators to produce consistent output. Processed material is discharged onto the rear conveyor for clean, controlled stockpiling.

Built on a compact, heavy-duty chassis, the AG700 is easily transported between sites, making it ideal for smaller projects, confined spaces and general contractor use.

-  **Versatility.** Handles a wide range of materials across multiple applications.
-  **Innovation.** Modern design with efficient power delivery and quick setup.
-  **Performance.** Consistent output with low running costs & easy maintenance access.

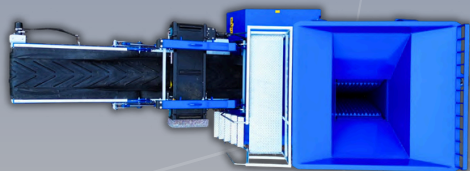

AG700 Technical Specifications

Drawings & Key Dimensions

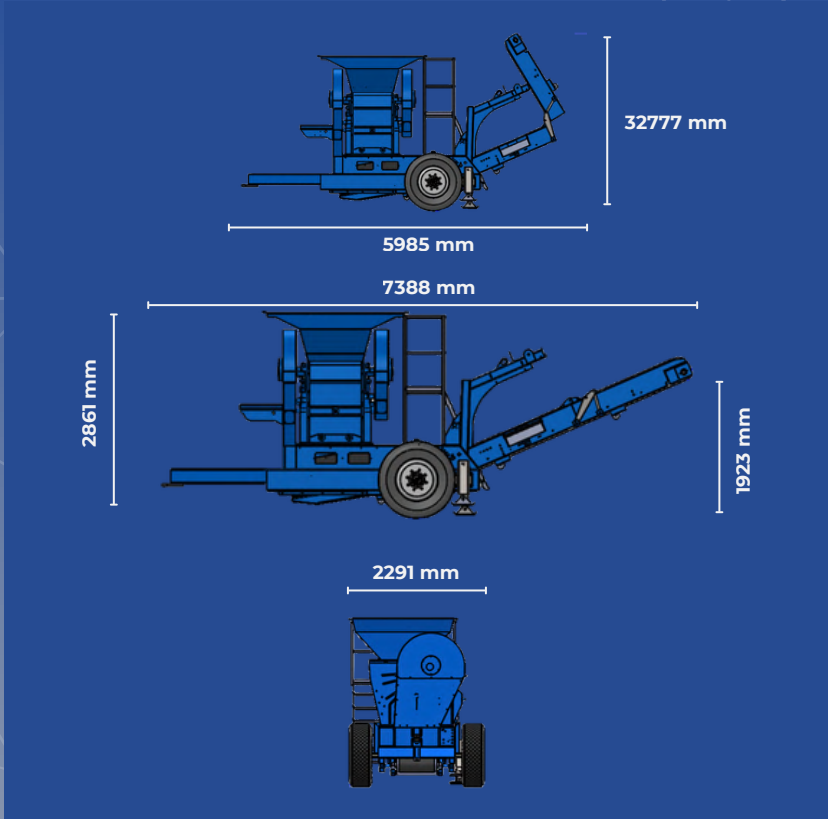

Transport & Working Dimensions

Transport Length / Width / Height (mm)	5900 / 2350 / 3100 (19' 4" / 7' 9" / 10' 2")
Working Length (including conveyor) (mm)	27350 / 2350 / 3100 (24' 1" / 7' 9" / 10' 2")
Jaw Size (mm)	700 × 400 (28" × 16")
Crush Size (mm)	40 – 125 (1½" – 5")
Hopper Width / Length (mm)	1870 / 1725 (6' 2" / 5' 8")
Feed Height from Ground Level (mm)	1923 (6' 4")
Power Source	Tractor PTO - 90 HP Minimum
Unladen Weight	8,500 kg



Materials Processed:

- Stone
- Concrete
- Brick
- Hardcore
- Demolition Waste
- Reclaimed Asphalt



AG700 Applications:

- Recycling
- Construction
- Demolition
- Groundworks
- Site Clearance
- Agricultural Crushing



+44 (0)28 8077 1568



+44 (0) 7880 073807



info@herbst.co.uk

