

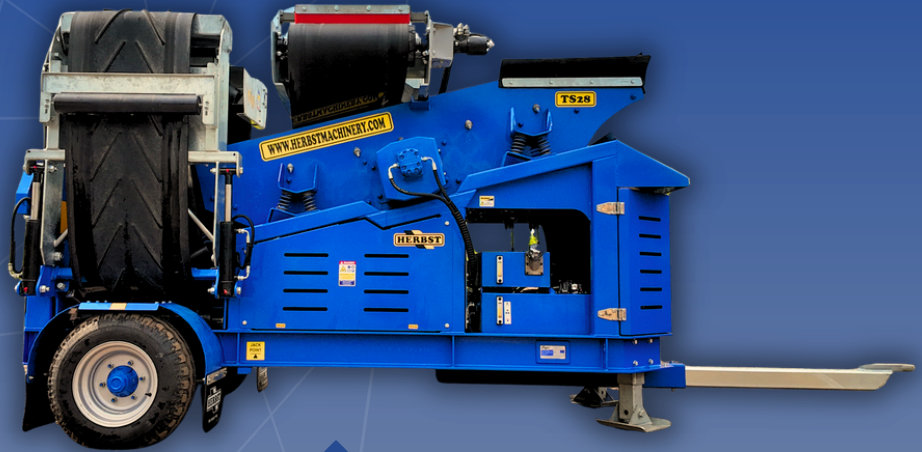

TS28

SCREENER



HERBST TS28 SCREENER

Compact. Versatile. Efficient by design.

- High performance single deck screener
- Towable behind tractor or crusher
- Diesel powered hydraulic system
- Folding fines & oversize conveyors
- 2.2 m x 1 m screen box
- Stage 5 diesel powerpack
- Hydraulic telescopic drawbar
- Simple setup & easy transport
- Unladen weight: 3,750 kg

TS28 Applications:

Recycling, Construction,
Demolition, Landscaping,
Soil Processing, Aggregates

Materials Processed:

Aggregate, Gravel, Sand
Soil & Compost, Crushed
Rubble, Wood Chip



Got Questions? Scan to
chat on WhatsApp!





Scan for video
demonstrations

TS28 Overview

The TS28 is a compact and versatile screening solution designed for efficient on-site material processing. Towable behind a tractor or crusher, the machine is quick to deploy and ideal for recycling, construction, landscaping and aggregate applications.

Its high performance single deck screen box, combined with folding discharge conveyors and a compact transport footprint, allows the TS28 to deliver reliable screening performance while remaining easy to transport between sites.

Powered by a Stage 5 diesel hydraulic system, the TS28 offers straightforward operation, low running costs and simple maintenance access.

-  **Versatility.** Handles a wide range of screening applications.
-  **Innovation.** Compact modern design with efficient setup.
-  **Performance.** Reliable and productive screening output with low running costs.



TS28 Technical Specifications

Drawings & Key Dimensions

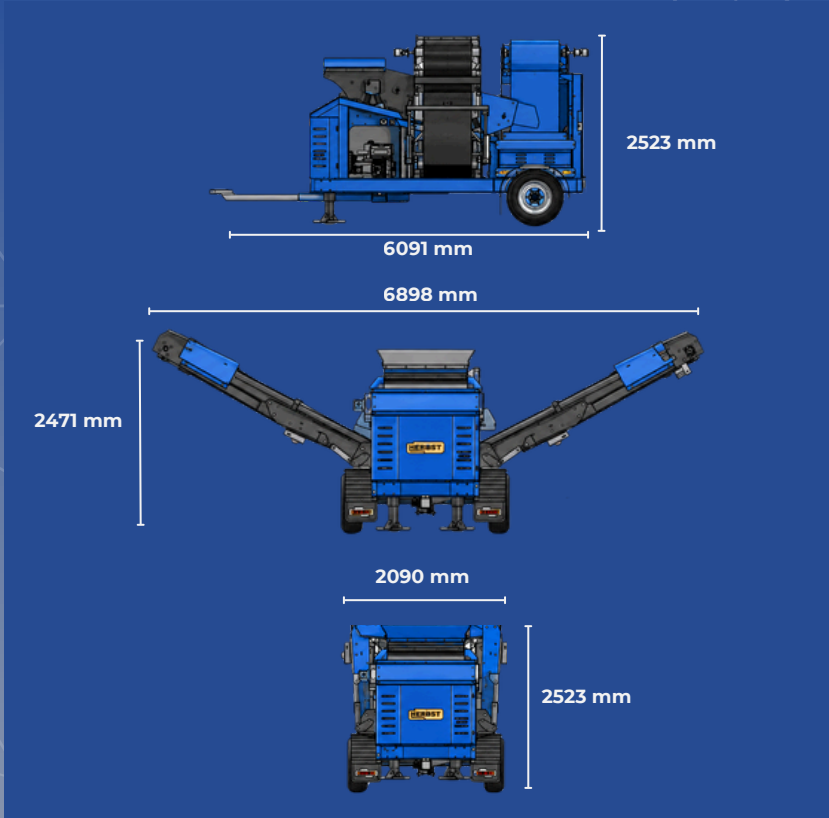

Transport & Working Dimensions

Transport Length / Width / Height (mm)	4928 / 2090 / 2523 (16' 2") / (6' 10") / (8' 3")
Working Length / Width / Height (mm)	6898 / 6091 / 2471 (22' 8") / (20' 0") / (8' 1")
Deck Size (mm)	2200 × 1000 (7' 2" × 3' 3")
Screening Media Options	Multiple Options Available
Loading Height (mm)	2100 (6' 10")
Stockpile Height (mm)	2120 (6' 11")
Powerpack	Stage V Diesel Engine
Unladen Weight	3,750 kg



Materials Processed:

- Aggregate
- Gravel
- Sand
- Soil & Compost
- Crushed Rubble
- Wood Chip



TS28 Applications:

- Recycling
- Construction
- Demolition
- Landscaping
- Soil Processing
- Aggregates



+44 (0)28 8077 1568



+44 (0) 7880 073807



info@herbst.co.uk

